



DIGITAL EVIDENCE RECORDER™



- 16 channel IP-based Network Video Recorder
- Operates with Jpeg, Mpeg2 and Mpeg4 IP-based devices
- TCP/IP based Data Recording Module for recording EPOS and other data
- Supports SNMP for total network integration
- Fully compatible with existing Visimetrics Control Software for Hybrid DVR/NVR Networks

Designed to operate with a number of different IP video devices, OCTAR Net is a powerful, high capacity NVR which can record and display video from up to 16 input sources which may even use different compression methods. This open architecture approach enables system designers to specify the most appropriate video codec or IP camera for any given surveillance task, with OCTAR fully integrating these into one platform.

With up to 4TB of on board Hard Disk Capacity, OCTAR net can leverage maximum effectiveness from today's high frame rate, high resolution IP-based cameras and servers, all managed by a highly developed, robust user interface. As well as being at the cutting edge of IP-based technology, the audit files, pass wording and handling of data transport for evidence ensure it fulfills its primary function as a provider of CCTV evidence, complying fully with HOSDB "Digital Images as Evidence" guidelines.

Product Range	OCTAR Net is supplied as a 16-channel desktop or rack mount unit. Hard disk capacities may be specified between 500GB and 4TB.
Recording Rates	Up to 25 IPS depending on source.
Resolution	Selectable : 720 x 576, 480 x 576, 352 x 288.
Compression Format	JPEG, MPEG2, MPEG4.
Storage Format	Various hard disk capacities from 500GB to 4TB.
Video Input	Video is streamed to OCTAR Net via IP network.
Video Output	Via CONTROL.
Audio Input	Audio is streamed to OCTAR Net via IP network.
Audio Output	1 x Mini Jack.
Data Recording	Up to 16 independent data channels may be recorded through serial ports or network links. Examples: Access Control, ANPR, EPoS, Bar Codes and Alarm data. Recorded data is synchronised with video and audio and is searchable for event retrieval and playback. Text overlay display may be toggled on/off during playback (via CONTROL software).
Alarm Input/Output	As supported by network device.
Network Ports	100baseT Ethernet link on RJ45 socket. Remote Access via LAN, WAN & ADSL. DHCP enabled. SNMP supported.
Serial Ports	1 x RS232. 9 pin D type.
Video Motion Detection	Integrated high performance VMD with zone-masking.
Recording Schedule	Programmable continuous and event recording according to time and weekday. Combined VMD/Timelapse mode.
Telemetry Support	As supported by network device.
Software Integration	Visimetrics Software Developers Kit (SDK) provides a powerful set of software components that enable third-party applications to integrate with OCTAR Net.
Image Export	Transfer of footage to CD/DVD RW. Transfer of required CONTROL software during disk creation for third party review by PC. Supports transfer to USB devices including memory stick and portable Hard Disk.
Other Features	Full operator log and evidential audit trail. Automatic restart after power fail. Hardware watchdog. Remote access and live viewing via Control Station or Control software.
Mains Power Input	200-240V AC 50Hz. 200W typical.
Operating Conditions	10 to 25C. Recommended temperature range 18 to 22C. 5% to 85% relative humidity.
Dimensions	W x H x D - 430mm x 175mm x 510mm.

Typical stand-alone OCTARnet application with IP cameras and camera servers

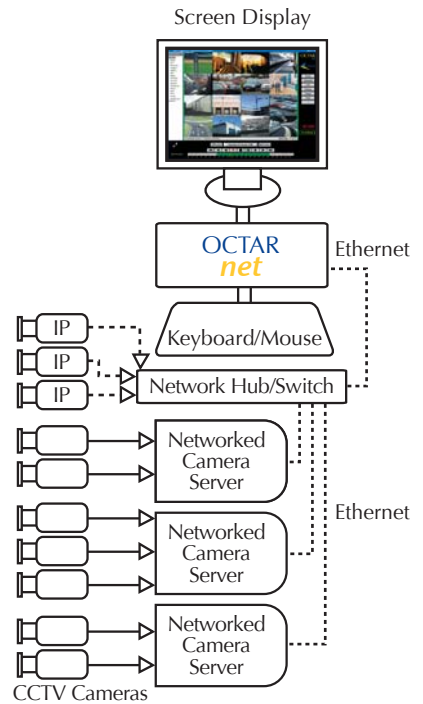

CONTROL user interface

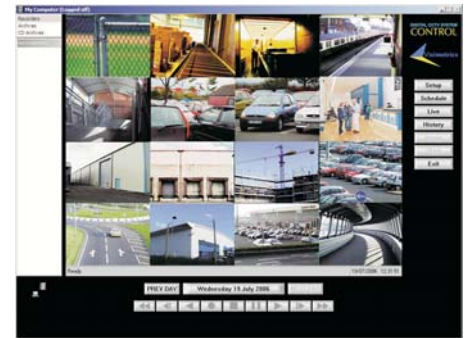

DIGITAL EVIDENCE RECORDER™

All Visimetrics DVR products now carry the **DIGITAL EVIDENCE RECORDER™** trademark. These DVRs are designed to record video, audio and data to the highest possible standards for evidential use, including encoding, time/date/serial number stamping, audit trail and easy, yet evidentially robust, data transport. Ask your dealer for our specially printed blank disks for evidential use.



DIGITAL CCTV SYSTEMS

Visimetrics (UK) Ltd
Skye House
Skye Road
Prestwick
KA9 2TA

Tel • +44 (0)1292 673 770

Fax • +44 (0)1292 677 990

e-mail • sales@visimetrics.com

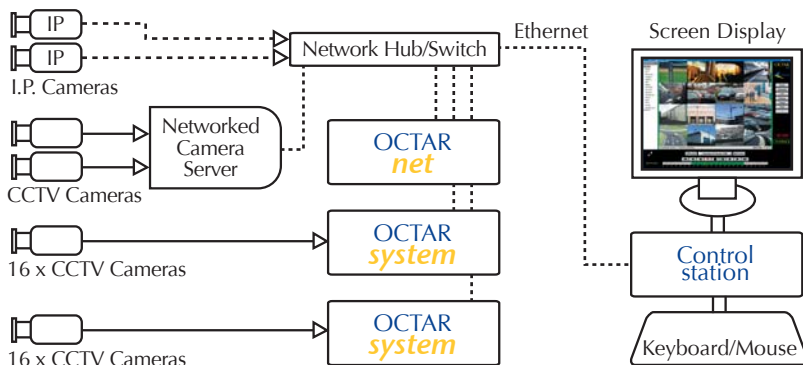

Integration of networked video recorders and "traditional" digital video recorders